

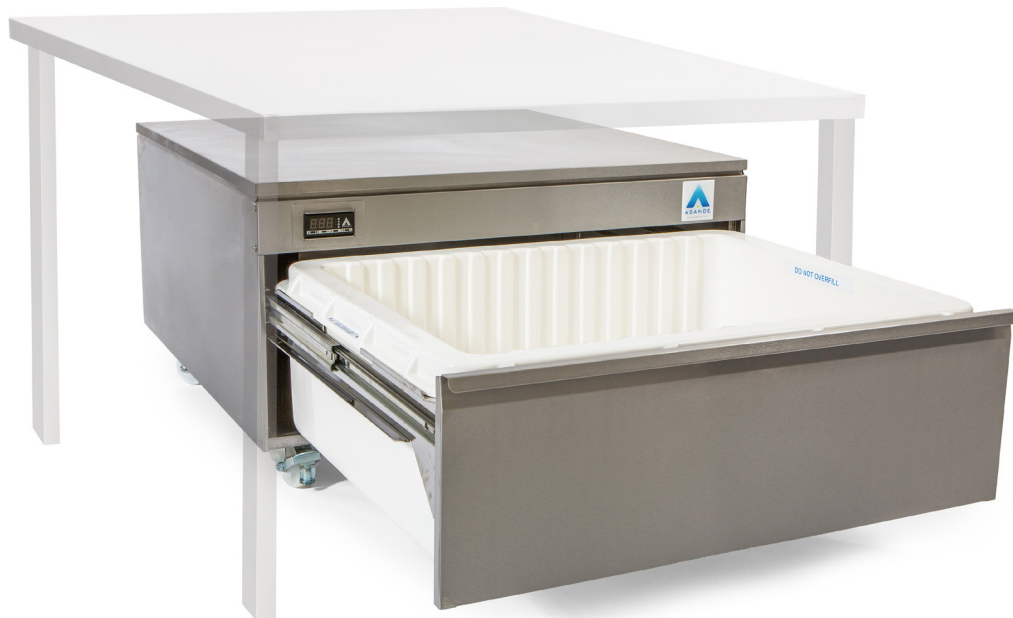

Under counter

Standard drawers + cover top



Applications

- Bulk storage right at the point of use
- Range of finished height units available, to suit a wide variety of spaces in the kitchen
- Unique patented Low Velocity Cooling keeps food fresher for longer

Storage Capacity

Gastronorm (GN) Pans
4 x 1/1 GN
100 mm Deep
or equivalent (per Drawer)

Maximum Weight
40 kg of Food (per Drawer)

Volume
86 Litres (per Drawer)

Hydrocarbon R600a Refrigerant

Standard drawer

'B' Energy Rating
in Freezer Mode

'A' Energy Rating
in Fridge Mode
(Consumption 307
kWh/annum)

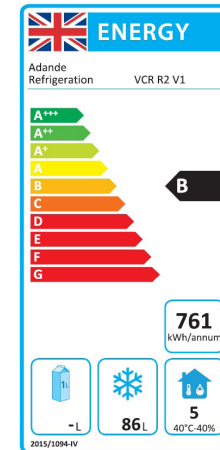

Climate Testing

Tested to **Climate Class 4**
(30°C & 55% relative humidity)
for temperature and energy
consumption and to **Climate
Class 5** (40°C & 40% relative
humidity) for temperature

Electrical

Mains Supply
230 Vac 50 Hz

Power Socket (included)
Correct 2 or 3 Pin Plug
fitted for each country

Mains Lead (included)
2 Metre Coiled Lead





Options

UNDER COUNTER + COVER TOP (T)	High castor base (HC)		Standard castor base (C)		Small castor base (SC)		Rollers & feet base (R)		Small rollers & feet base (SR)		Fixed frame base (FF)		Mobile frame base (MF)	
Finished height	565 mm	VCRI/HCT	494 mm	VCRI/CT	473 mm	VCRI/SCT	449 mm	VCRI/RT	439 mm	VCRI/SRT	590-900 mm	VCRI/FFT	590-900 mm	VCRI/MFT
Load-bearing capacity	0 kg		0 kg		0 kg		0 kg		0 kg		0 kg		0 kg	

For full options please see our [Drawer Customising and Accessories](#) pages

Plan View

Under counter (VCRI)
With open drawer

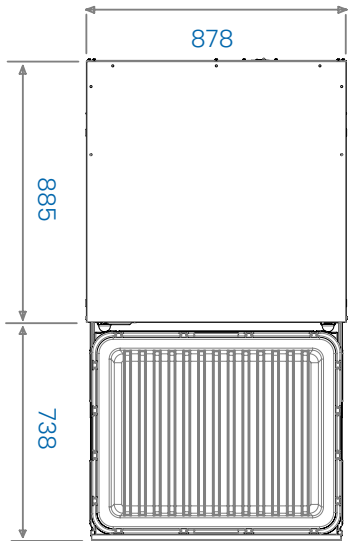

Elevation

Under counter (VCRI)
High castors (HC)
Cover top (T)
VCRI/HCT

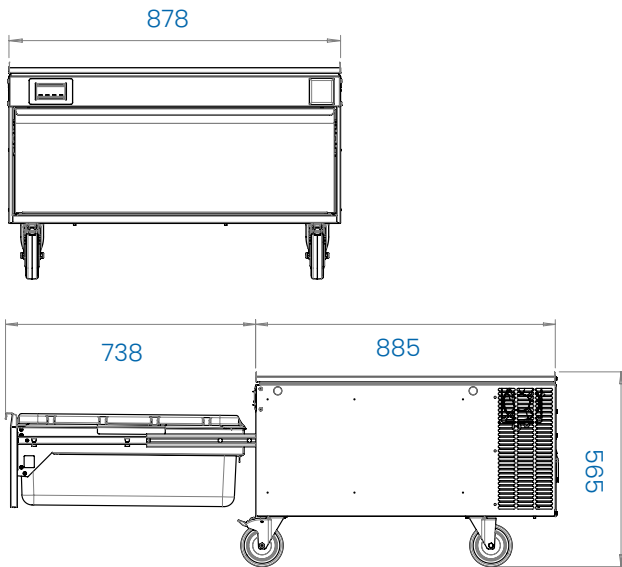

Tops



Drawer Module



Base

