



Under counter – fridge only

Standard drawer + cover top



Applications

- Bulk storage right at the point of use
- Range of finished height units available, to suit a wide variety of spaces in the kitchen
- Unique patented Low Velocity Cooling keeps food fresher for longer

Storage Capacity

Gastronorm (GN) Pans
4 x 1/1 GN
100 mm Deep
or equivalent (per Drawer)

Maximum Weight
40 kg of Food (per Drawer)

Volume
86 Litres (per Drawer)

Hydrocarbon R600a Refrigerant

A+ Fridge Drawer

'A+' Energy Rating
(Consumption 239
kWh/annum)

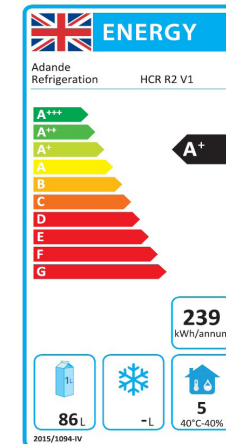

Climate Testing

Tested to **Climate Class 4**
(30°C & 55% relative humidity)
for temperature and energy
consumption and to **Climate
Class 5** (40°C & 40% relative
humidity) for temperature

Electrical

Mains Supply
230 Vac 50 Hz

Power Socket (included)
Correct 2 or 3 Pin Plug
fitted for each country

Mains Lead (included)
2 Metre Coiled Lead

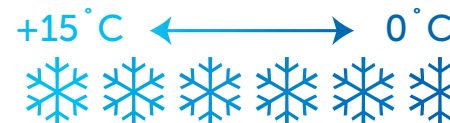



UNDER-COUNTER – FRIDGE ONLY – ONE DRAWER – REAR ENGINE – HCRI

Options

UNDER COUNTER + COVER TOP (T)	High castor base (HC)		Standard castor base (C)		Small castor base (SC)		Rollers & feet base (R)		Small rollers & feet base (SR)		Fixed frame base (FF)		Mobile frame base (MF)	
Finished height	565 mm	HCRI/HCT	494 mm	HCRI/CT	473 mm	HCRI/SCT	449 mm	HCRI/RT	439 mm	HCRI/SRT	590-900 mm	HCRI/FFT	590-900 mm	HCRI/MFT
Load-bearing capacity	0 kg		0 kg		0 kg		0 kg		0 kg		0 kg		0 kg	

For full options please see our [Drawer Customising and Accessories](#) pages

Plan View

Under counter
A+ fridge only (HCRI)
With open drawer

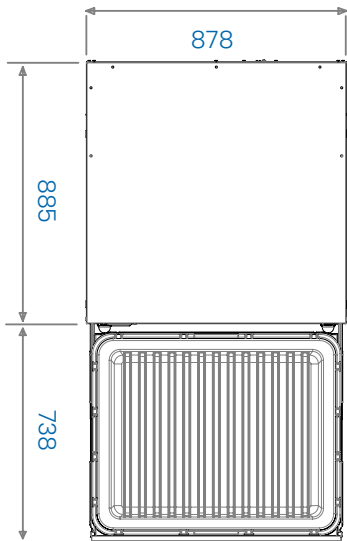

Elevation

Under counter
A+ fridge only (HCRI)
Standard castors (C)
Cover top (T)
HCRI/CT

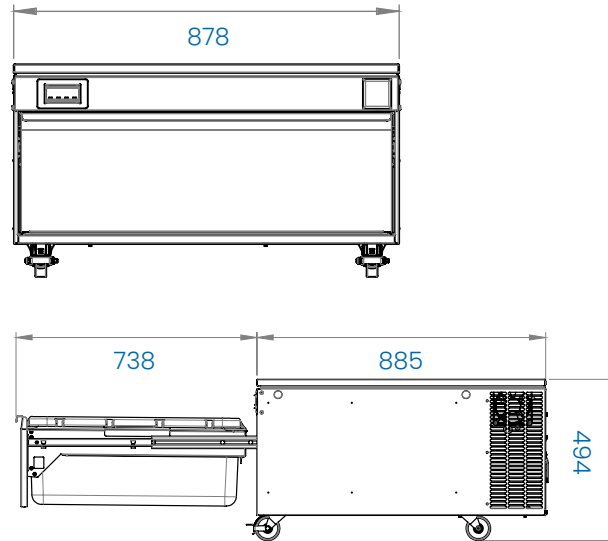

Tops



Drawer Module



Base

