



## Matchbox cassette drawer

Standard drawer + cover top



### Blast Chill

For added functionality a BC option is available with this spec Drawer

## Applications

- Highly ergonomic storage solution, right at the point of use
- Matchbox Drawers provide access from both sides of a central island unit
- Ideal for meat, deli and dessert prep
- Perfect storage for garnish and 'mise en place' generally

### Storage Capacity

**Gastronorm (GN) Pans**  
4 x 1/1 GN  
100 mm Deep  
or equivalent (per Drawer)

**Maximum Weight**  
40 kg of Food (per Drawer)

**Volume**  
86 Litres (per Drawer)

### Climate Testing

Tested to **Climate Class 4**  
(30°C & 55% relative humidity)  
for temperature and energy consumption and to **Climate Class 5** (40°C & 40% relative humidity) for temperature

### Electrical

**Mains Supply**  
230 Vac 50 Hz

**Power Socket** (included)  
Correct 2 or 3 Pin Plug fitted for each country

**Mains Lead** (included)  
2 Metre Coiled Lead

### Hydrocarbon R600a Refrigerant

#### Standard drawer

'B' Energy Rating in Freezer Mode

'A' Energy Rating in Fridge Mode  
(Consumption 307 kWh/annum)

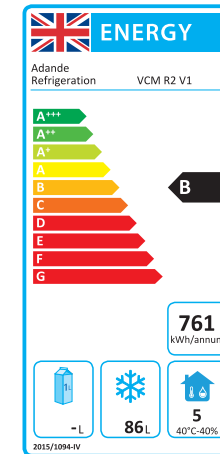



## Options

MATCHBOX + SOLID WORKTOP (W)	Flat base (FB)	
Finished height	428 mm	VCMI/FBW
Load-bearing capacity	Check weight capacity of cook range or other fabricated housing of the Adande Cassette unit	

MATCHBOX + COVER TOP (T)	Flat base (FB)	
Finished height	419 mm	VCMI/FBT
Load-bearing capacity	Check weight capacity of cook range or other fabricated housing of the Adande Cassette unit	

For full options please see our [Drawer Customising and Accessories](#) pages

## Plan View

Matchbox drawer cassette (VCMI)  
With open drawer

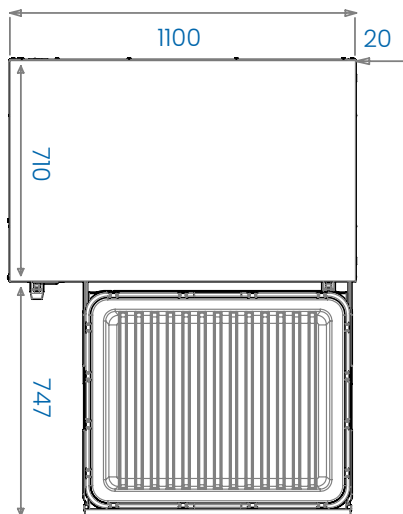

## Elevation

Matchbox drawer cassette (VCMI)  
Flat base (FB)  
Solid worktop (W)  
VCMI/FBW

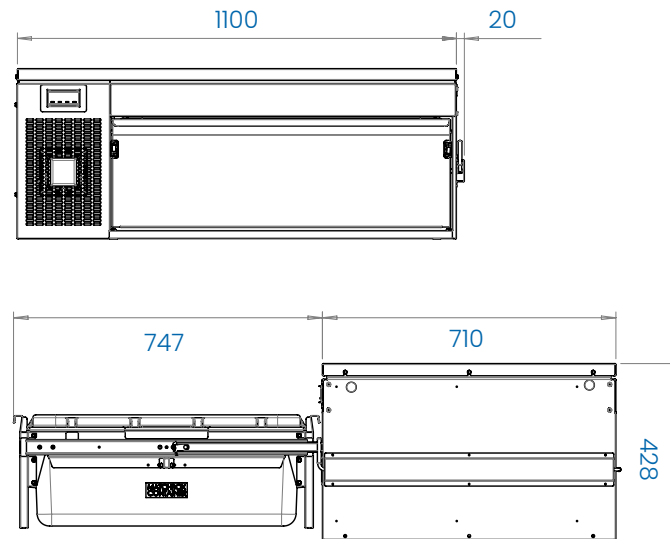

## Tops



## Drawer Module



## Base

